

**PRODUCT
CATALOGUE**

**CATALOGUE
DES PRODUITS**

PERFILSTAR

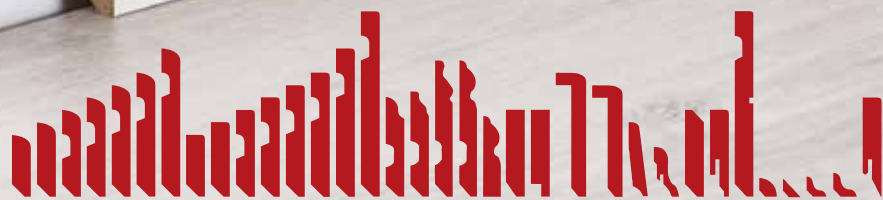
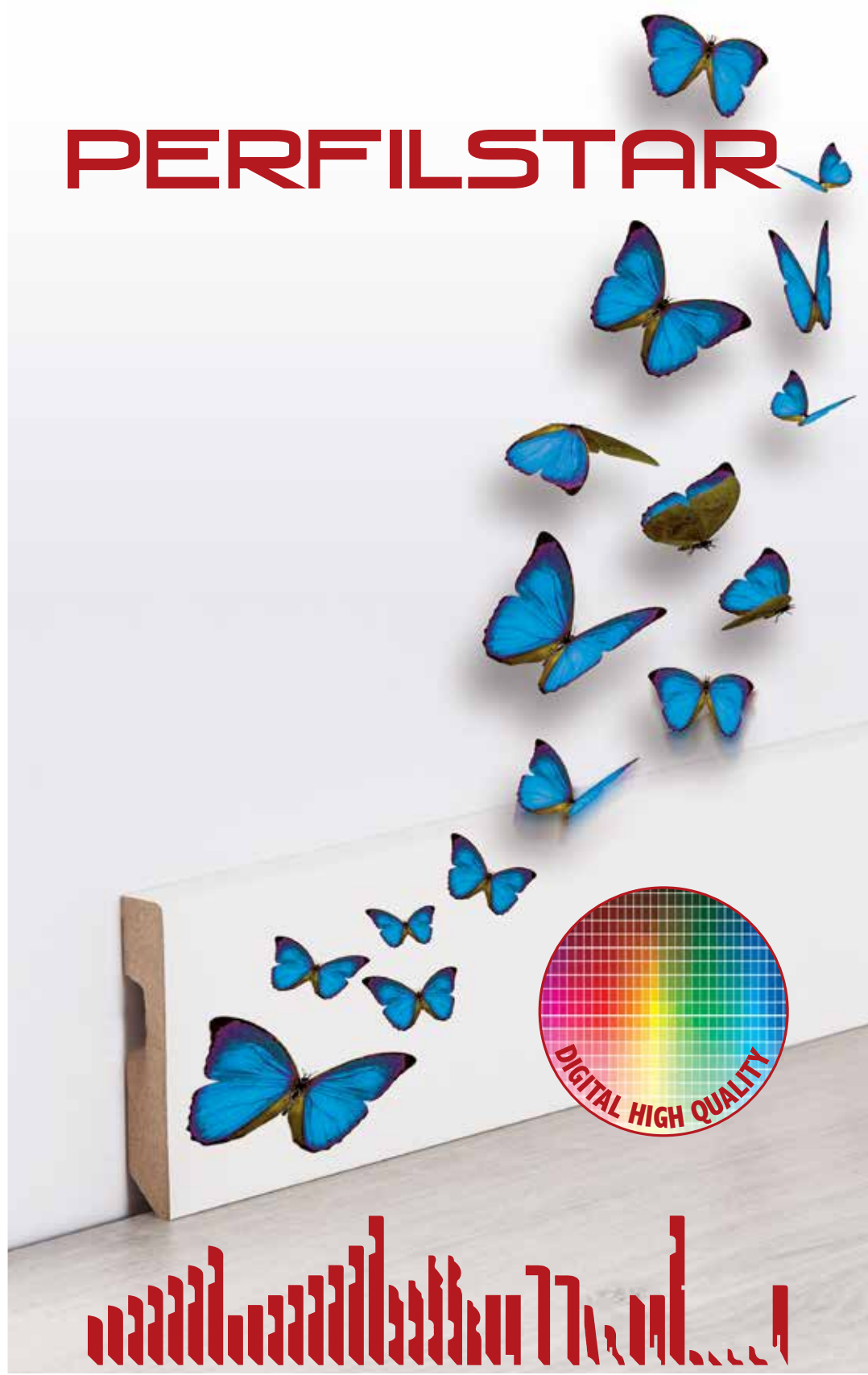

www.perfilstar.com

We complete your business

WE PRODUCE ALL DIGITAL FROM MORE THAN TEN YEARS / NOUS PRODUISONS TOUT EN DIGITAL DEPUIS PLUS DE 10 ANS

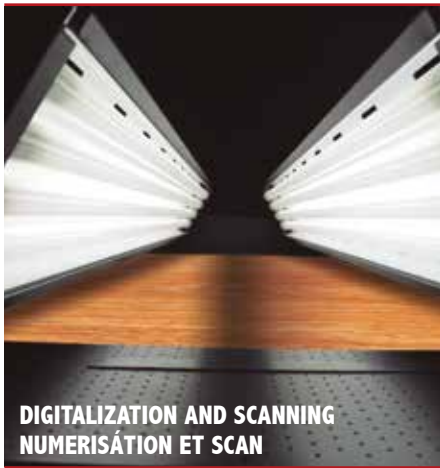

**DIGITALIZATION AND SCANNING
NUMÉRISATION ET SCAN**

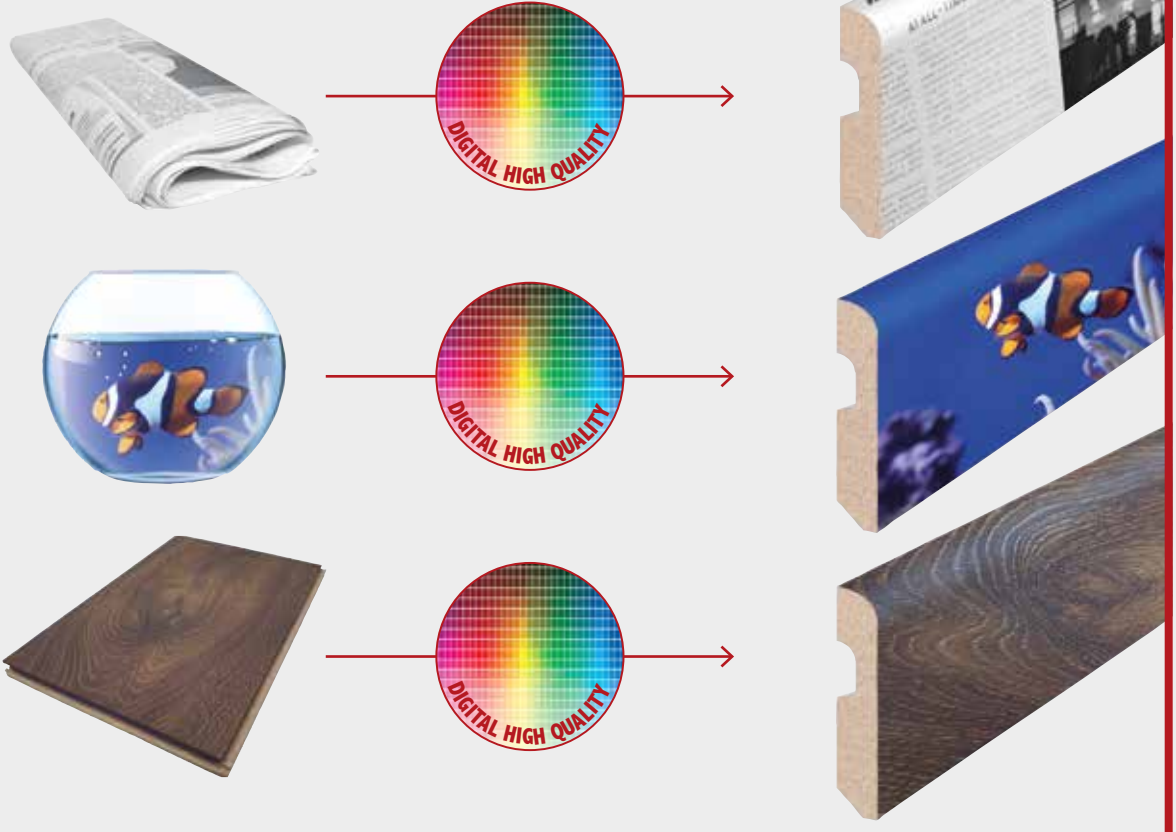

**IMAGE MODIFICATION
MODIFICATION DE L'IMAGE**



**COPIES AND SAMPLES
CONTRE-TYPES ET ÉCHANTILLONS**

**ALL
YOU
CAN
IMAGINE
WE
CAN
DO
IT**



FULL CUSTOMIZATION OF OUR PRODUCTS / PERSONNALISATION COMPLÈTE DE NOS PRODUITS



**EAN CODE
CODE EAN**



**LOGO COMPANY
LOGO DE L'ENTREPRISE**



**PRODUCT DESCRIPTION
DESCRIPTION DU PRODUIT**

FLOORING MATCHING



PERFILSTAR



FLOORING SAMPLES
ÉCHANTILLONS DE SOLS

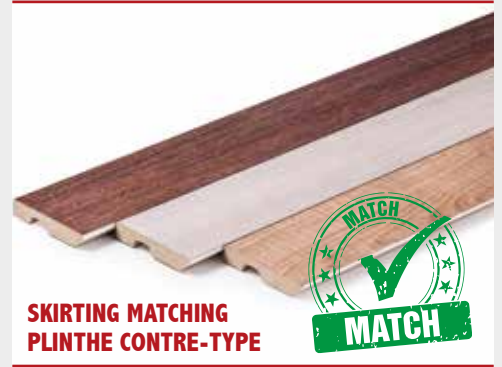

SKIRTING MATCHING
PLINTHE CONTRE-TYPE



**YOUR
COMPANY**

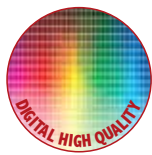

Laminate Flooring
Sol Stratifié



Wood Parket
Sol Placage Bois



LVT / Vinyl / SPC Flooring
Sol LVT / Vinyle / SPC

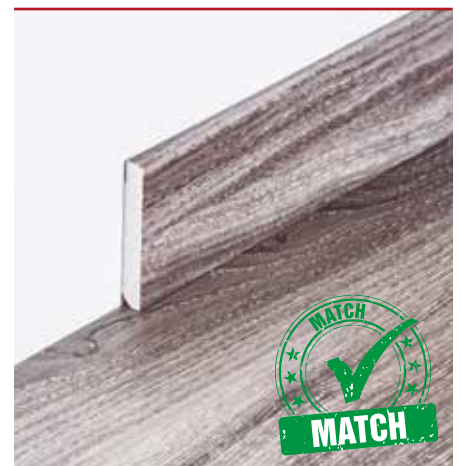

LAMINATE / STRATIFIÉ

LAMINATE FLOORING SECTION / SECTION DE SOL STRATIFIÉ



we match your flooring collection

www.perfilstar.com

DIGITAL LAMINATE SKIRTING / PLINTE STRATIFIÉ DIGITAL





Technical Features / Caracteristiques Techniques

Finish / Finition	Digital laminate / Stratifié digital
Support / Support	MDF / MDF
Adhesive / Adhésif	EVA / EVA
Length / Longueur	2250 mm / 88,5 in

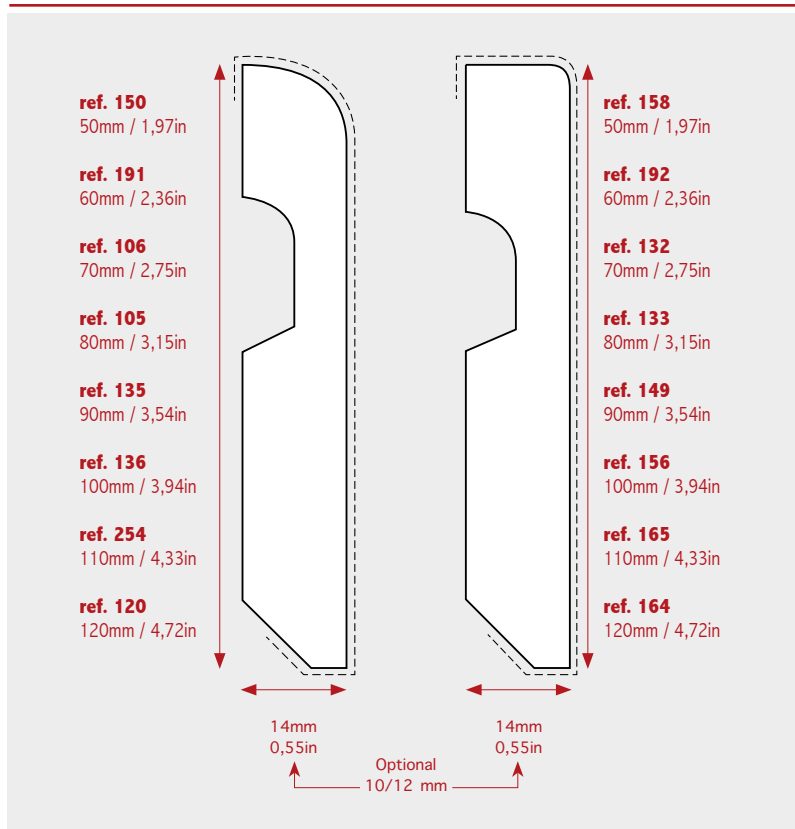
Measures / Mesures



- MDF 
- MDF 
- Moisture resistant MDF 
- MDF Hidrofuge 



CLICK SYSTEM SKIRTING / PLINTE SYSTÈME CLICK



Technical Features / Caracteristiques Techniques

Finish / Finition	Digital laminate / Stratifié digital
Support / Support	MDF / MDF
Adhesive / Adhésif	EVA / EVA
Length / Longueur	2250 mm / 88,5 in

Measures / Mesures

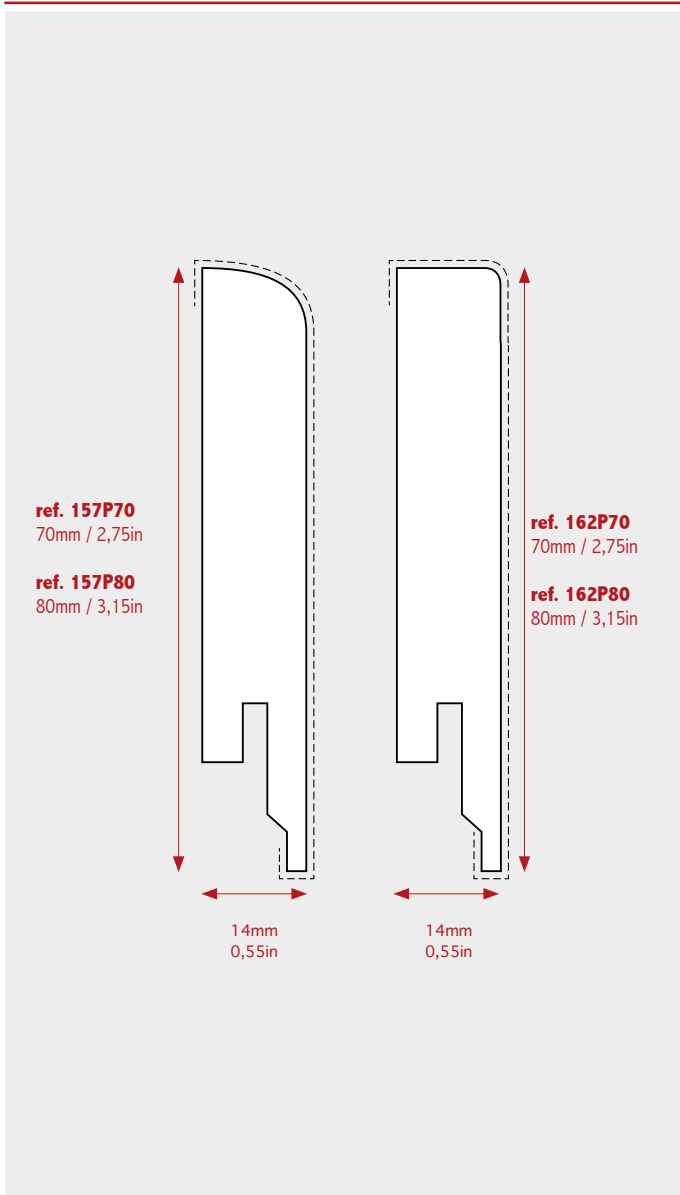

MDF 

Moisture resistant MDF
MDF Hidrofuge 

ref. 160-7



METAL CLIP
CLIP MÉTALLIQUE

ref. 181

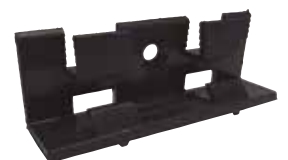

PLASTIC CLIP
CLIP EN PLASTIQUE

COVER SKIRTING / SURPLINTHE



Technical Features / Caracteristiques Techniques

Finish / Finition	Digital laminate / Stratifié digital
Support / Support	MDF / MDF
Adhesive / Adhésif	EVA / EVA
Length / Longueur	2440 mm / 96 in

Measures / Mesures

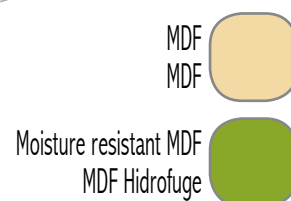
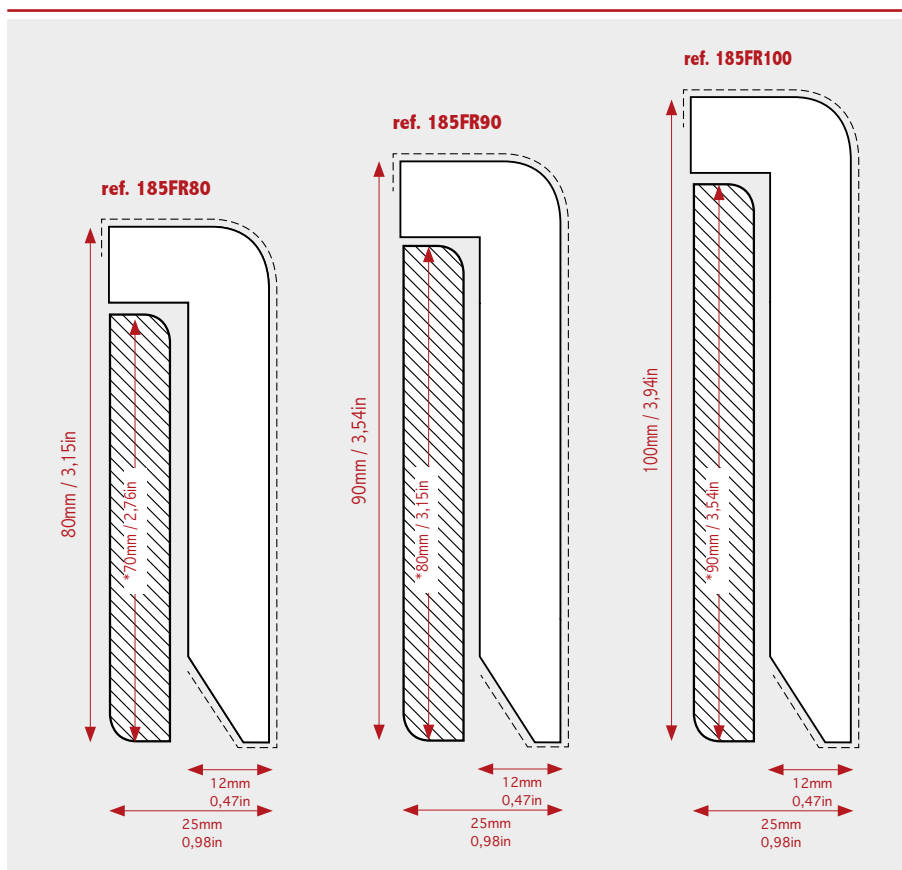

LAMINATE BASICS / BASIC STRATIFIÉ



ref. L-2322

White lacquered laminate

Blanc laqué stratifié



ref. L-99

RAL 9003

White laminate

Blanc Stratifié

ref. L-0

RAL 9003

Ready to Paint

Prêt a peindre



ref. L-1900

RAL 9016

White laminate

Blanc Stratifié



ref. L-1111

RAL 9010

White laminate

Blanc Stratifié



ref. L-1371

Metall laminate

Metallique stratifié



ref. L-100

RAL 9004

Black laminate

Noir stratifié



ref. L-1873 RAL 9010 Bright

White high bright

Blanc brillant

 GLOSS 80



ASK ANY LAMINATE COLOR
DEMANDER QUELLE COULEUR DE STRATIFIÉ

LAMINATE JOINT MDF HIDRO / BARRE DE SEUIL MDF HIDRO STRATIFIÉ

Technical Features / Caracteristiques Techniques

Finish / Finition	Hight resistance digital laminate / Stratifié digital haute resistance
Support / Support	Moisture Resistant MDF / MDF Hidrofuge
Adhesive / Adhésif	PUR / PUR
Length / Longueur	2440 mm / 96 in

Measures / Mesures

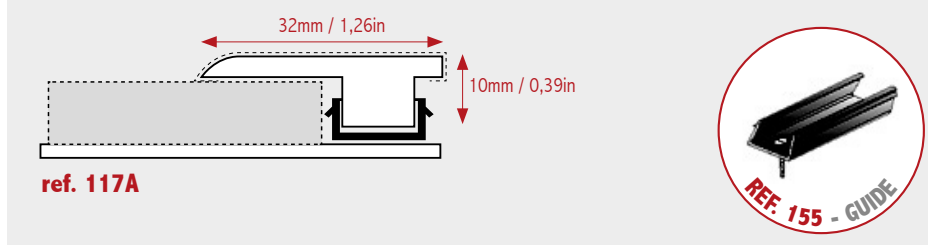
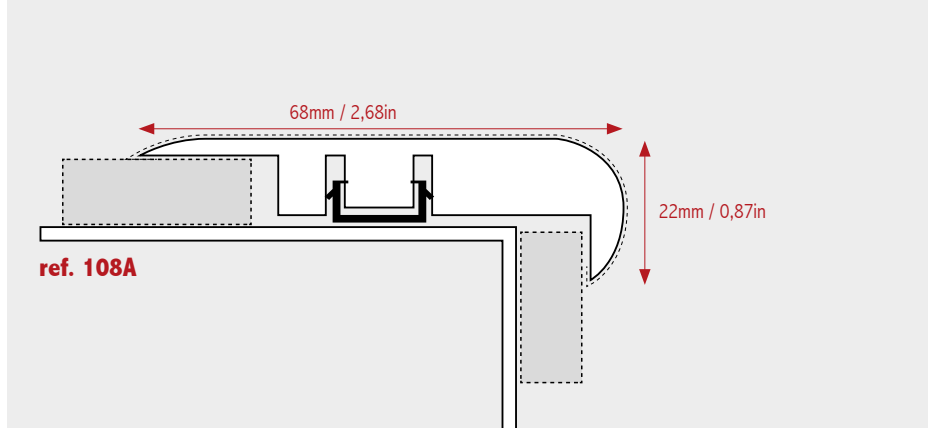
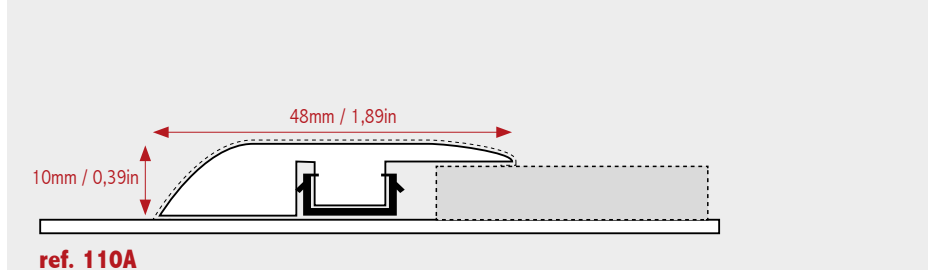
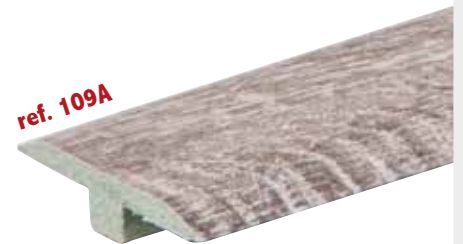
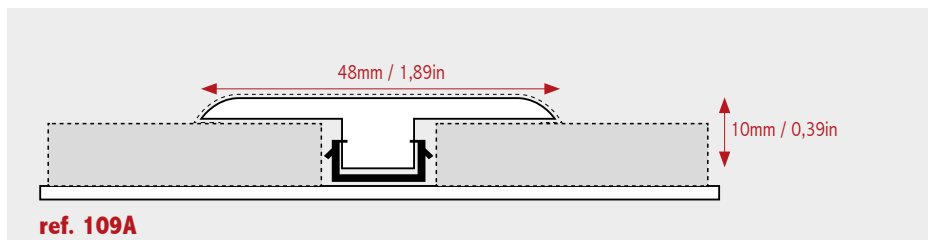
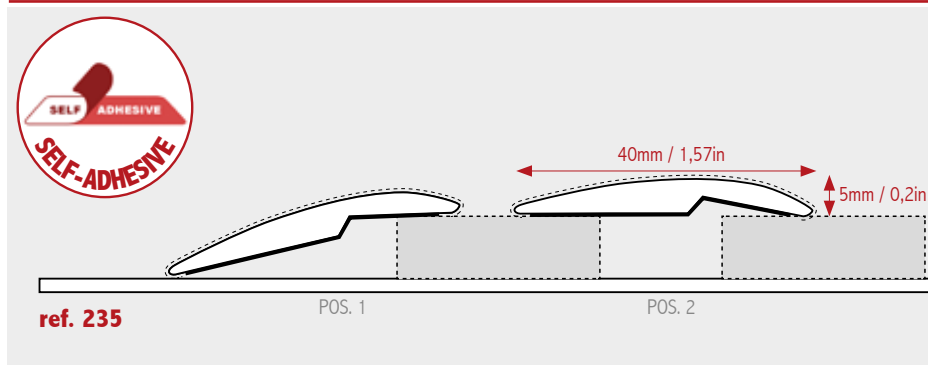

Moisture resistant MDF
MDF Hidrofuge



LAMINATE ALUMINIUM JOINT / BARRE DE SEUIL ALUMINIUM STRATIFIÉ

Technical Features / Caractéristiques Techniques

Finish / Finition	Hight resistance digital laminate / Stratifié digital haute resistance
Support / Support	Aluminium
Adhesive / Adhésif	PUR / PUR
Length / Longueur	2700 mm / 106,30 in

Measures / Mesures

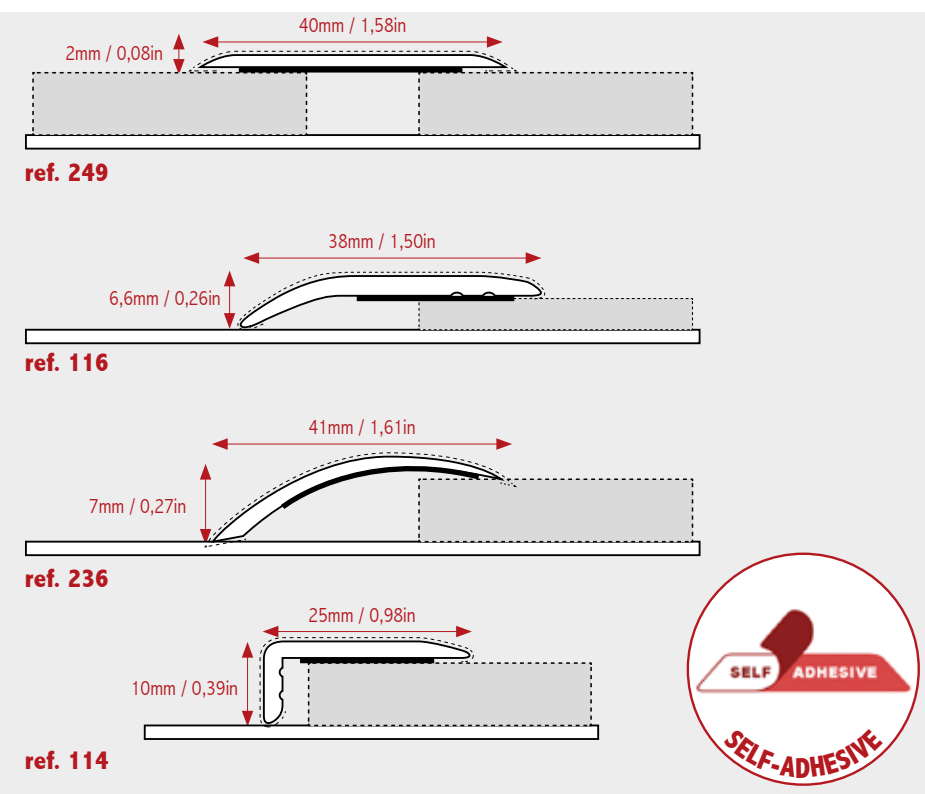
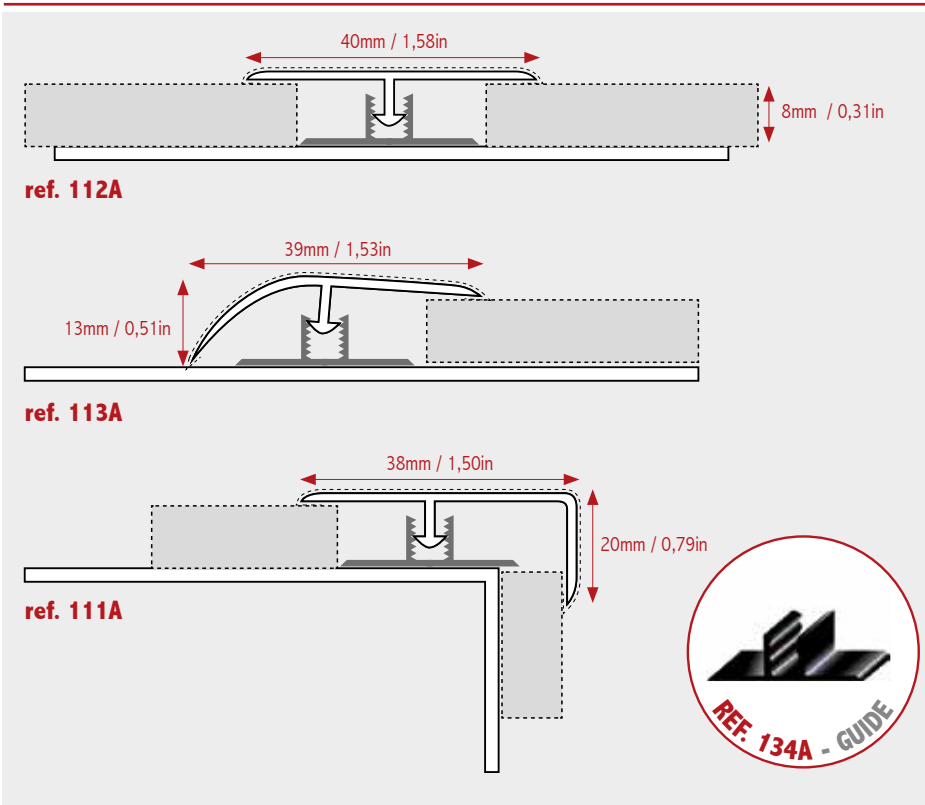

Aluminium
Aluminium





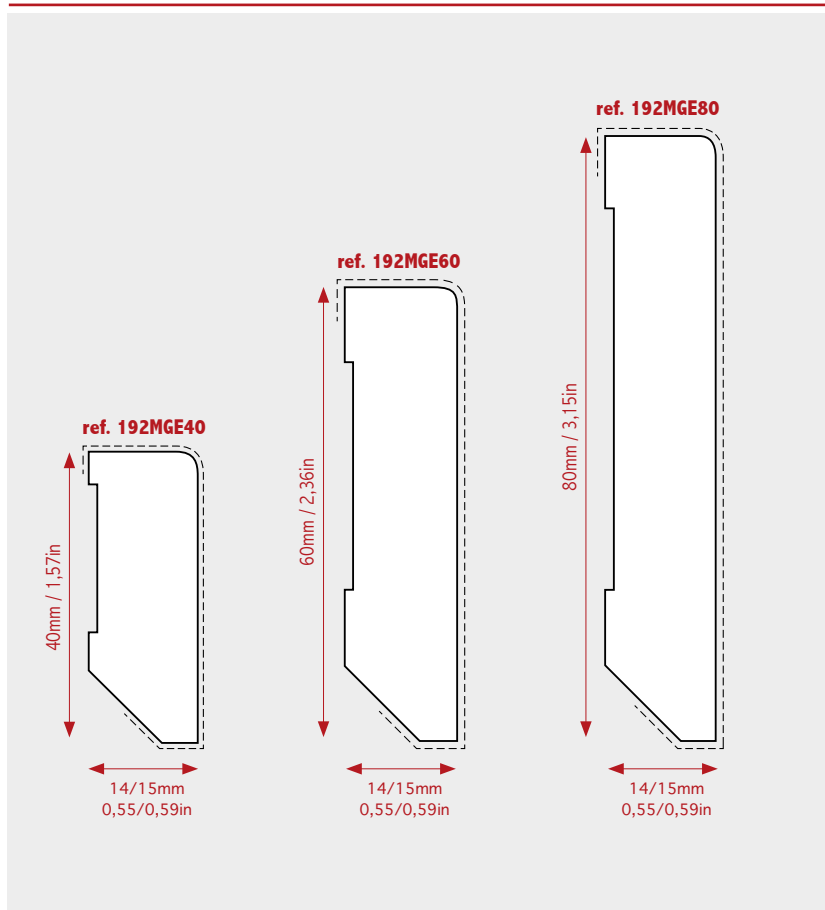

LEISTEN GERMANIC SKIRTING

Technical Features / Caracteristiques Techniques

Finish / Finition	Digital laminate/ Stratifié digital
Support / Support	Pine or MDF / Pin ou MDF
Adhesive / Adhésif	EVA / EVA
Length / Longueur	2480 mm / 97,63 in

Measures / Mesures



- MDF 
- MDF 
- Moisture resistant MDF 
- MDF Hidrofuge 
- Pine Finger Joint 
- Pin Abouté 

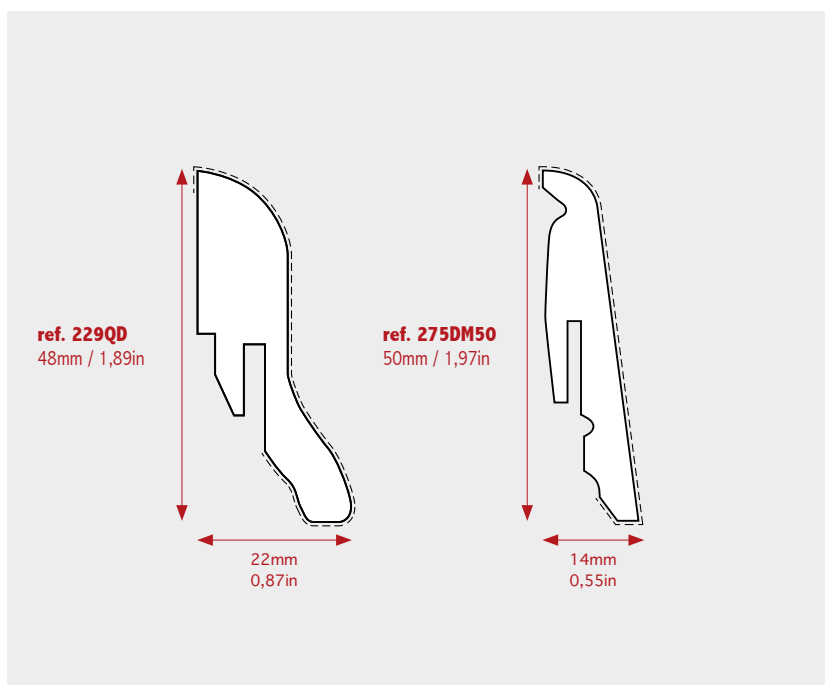

ref. 160-7



**METAL CLIP
CLIP MÉTALLIQUE**

ref. 181

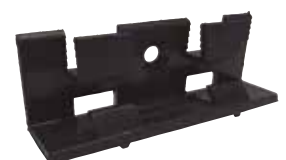

**PLASTIC CLIP
CLIP EN PLASTIQUE**





SKIRTING XXL / PLINTHE XXL

Technical Features / Caracteristiques Techniques

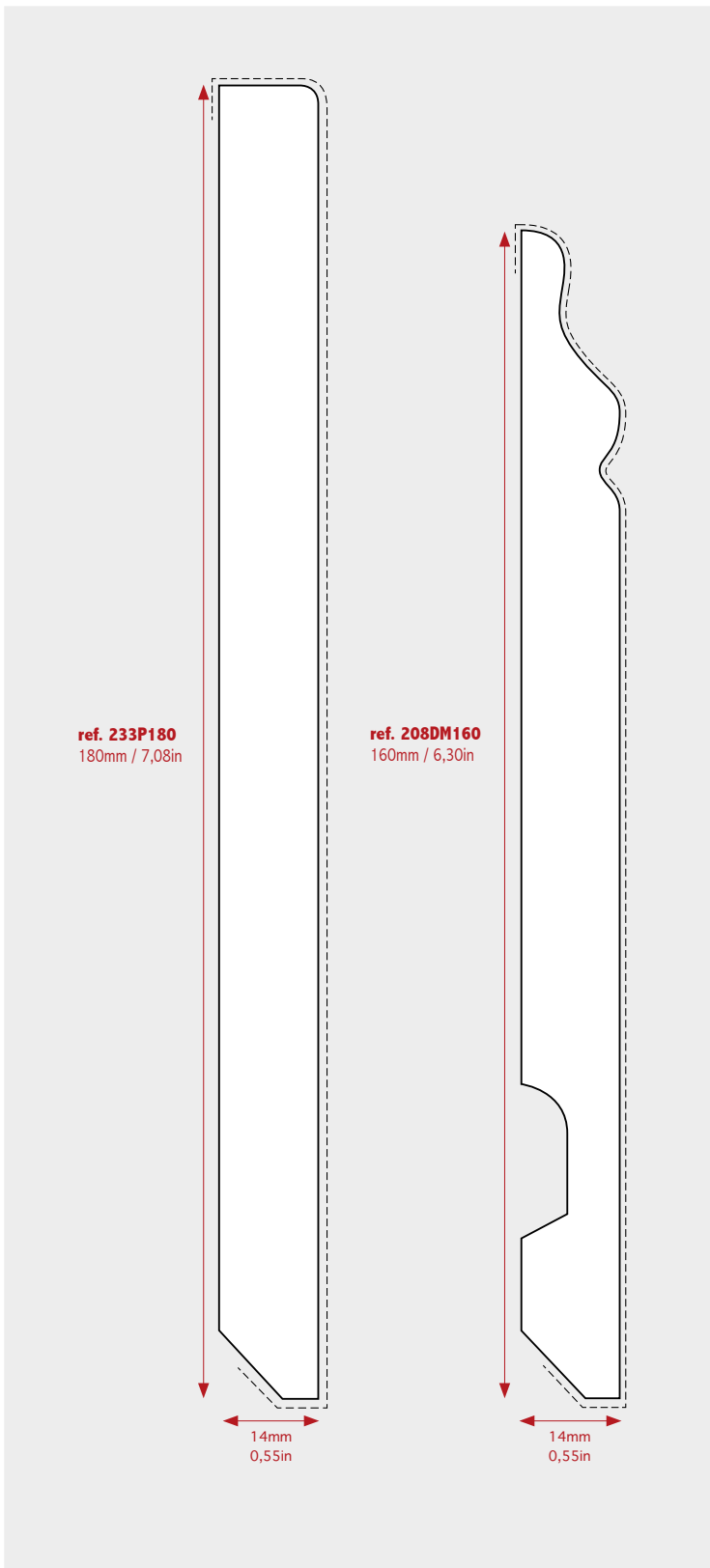
Finish / Finition	Digital laminate / Stratifié digital
Support / Support	MDF / MDF
Adhesive / Adhésif	EVA / EVA
Length / Longueur	2250 mm / 88,5 in

Measures / Mesures



- MDF 
- MDF 
- Moisture resistant MDF 
- MDF Hidrofuge / Anti Humidité 
- Pine Finger Joint 
- Pin Abouté

SKIRTING WITH WEATHER STRIP / PLINTE AVEC COUPE-FROID

Technical Features / Caracteristiques Techniques

Finish / Finition	Digital laminate / Stratifié digital
Support / Support	MDF / MDF
Adhesive / Adhésif	EVA / EVA
Length / Longueur	2250 mm / 88,5 in

Measures / Mesures

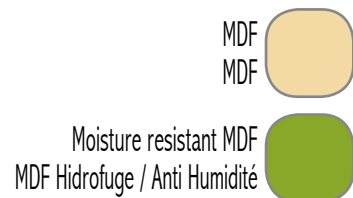
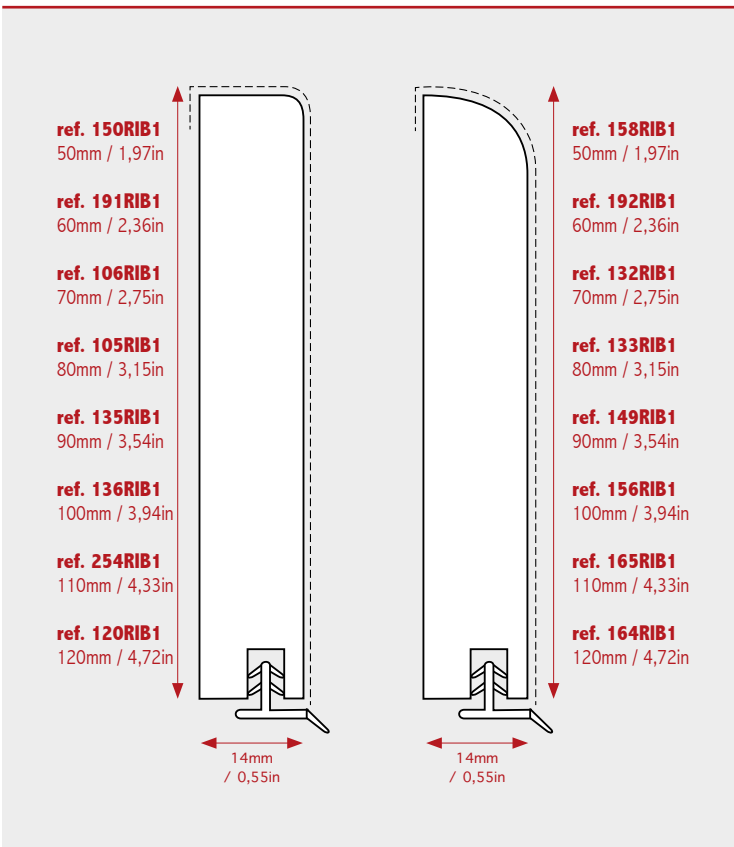

VICTORIAN SKIRTING / VICTORIENNE PLINTE

Technical Features / Caractéristiques Techniques

Finish / Finition	Digital laminate / Stratifié digital
Support / Support	MDF / MDF
Adhesive / Adhésif	EVA / EVA
Length / Longueur	2250 mm / 88,5 in

Measures / Mesures

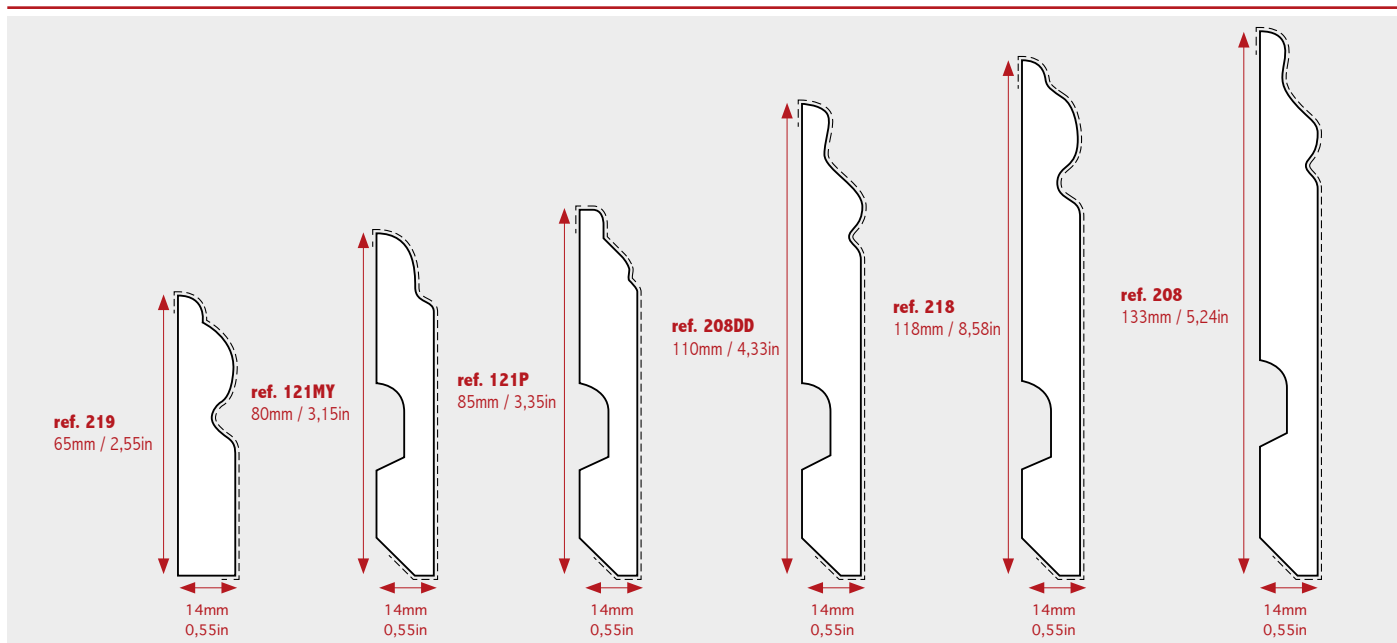

SCOTIA / SCOTIA

Technical Features / Caractéristiques Techniques

Finish / Finition	Digital laminate / Stratifié digital
Support / Support	MDF / MDF
Adhesive / Adhésif	EVA / EVA
Length / Longueur	2440 mm / 96,06 in

Measures / Mesures



DIGITAL PVC SKIRTING / PLINTE PVC DIGITALE

Technical Features / Caracteristiques Techniques

Finish / Finition	Digital PVC / PVC digital
Support / Support	MDF or Plywood or Pine FJ / MDF ou contreplaqué ou Pin
Adhesive / Adhésif	PUR / PUR
Length / Longueur	2250 mm / 88,58 in (mdf or pine) 2500 mm / 98,42 ind (plywood ou pin)



Measures / Mesures

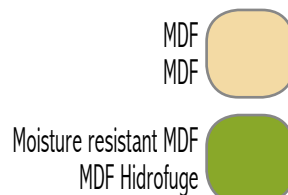
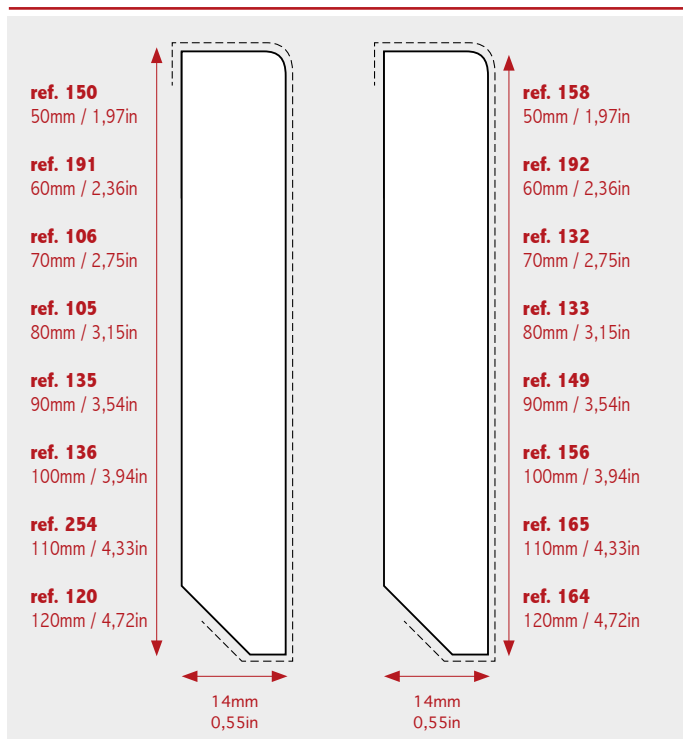

Acrylic Vinyl foil (PVC) with 150µm = 0,15mm thickness and decor digitally printed.
Feuille de Vinyle acrylique (PVC) de 150µm = 0,15mm d'épaisseur et décor imprimé digital.

PLYWOOD / CONTREPLAQUÉ



PVC Digital Foil
Revetue PVC Digital

Lacquered Foil
Papier Lacqué

Wood Veneer
Placage Bois



PINE FINGER JOINT / PIN ABOUTÉ



PVC Digital Foil
Revetue PVC Digitale

Lacquered Foil
Papier Lacqué

Lacquered
Lacqué

Wood Veneer
Placage Bois



best waterproof solution

WATER RESISTANT SKIRTING / RÉSISTANT À L'EAU

PVC COMPACT SKIRTING / PLINTE PVC COMPACT

VINYL LVT FLOORING SECTION / SECTION VINYLE



www.perfilstar.com



Technical Features / Caracteristiques Techniques

Finish / Finition	Digital laminate / Stratifié digital
Support / Support	PVC Compact / PVC Compact
Adhesive / Adhésif	PUR / PUR
Length / Longueur	2050 mm / 80,70 in

Measures / Mesures

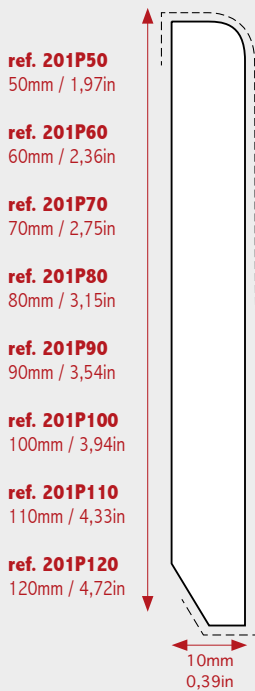

Compact PVC
PVC Compact



PVC COMPACT SKIRTING / PLINTE PVC COMPACT

15mm



Technical Features / Caracteristiques Techniques

Finish / Finition	Digital laminate / Stratifié digital
Support / Support	PVC Compact / PVC Compact
Adhesive / Adhésif	PUR / PUR
Length / Longueur	3050 mm / 120,07 in

Measures / Mesures

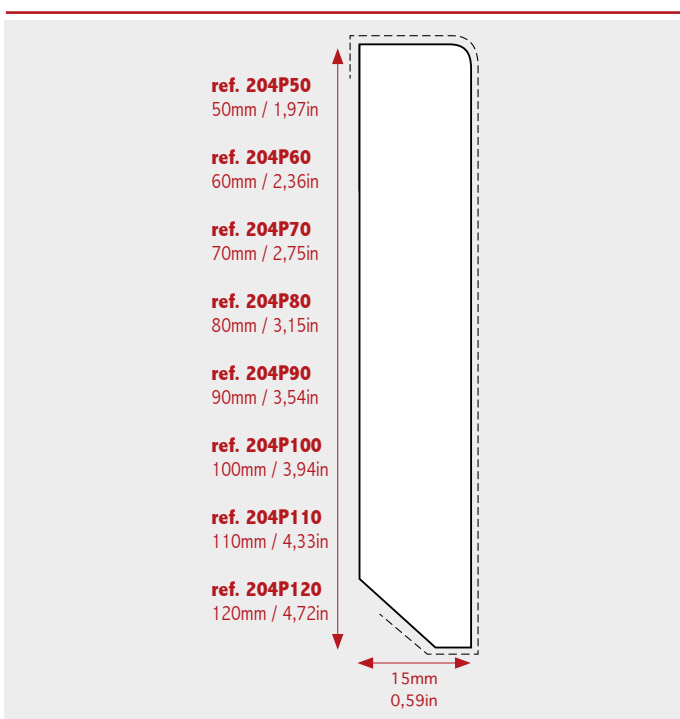

Compact PVC
PVC Compact



OPTIONAL
12mm

DIGITAL HIGH QUALITY

WHITE PVC COMPACT SKIRTING / PLINTE BLANCHE PVC COMPACT



Compact PVC
PVC Compact



Technical Features / Caracteristiques Techniques

Finish / Finition

White laminate / Blanche stratifié

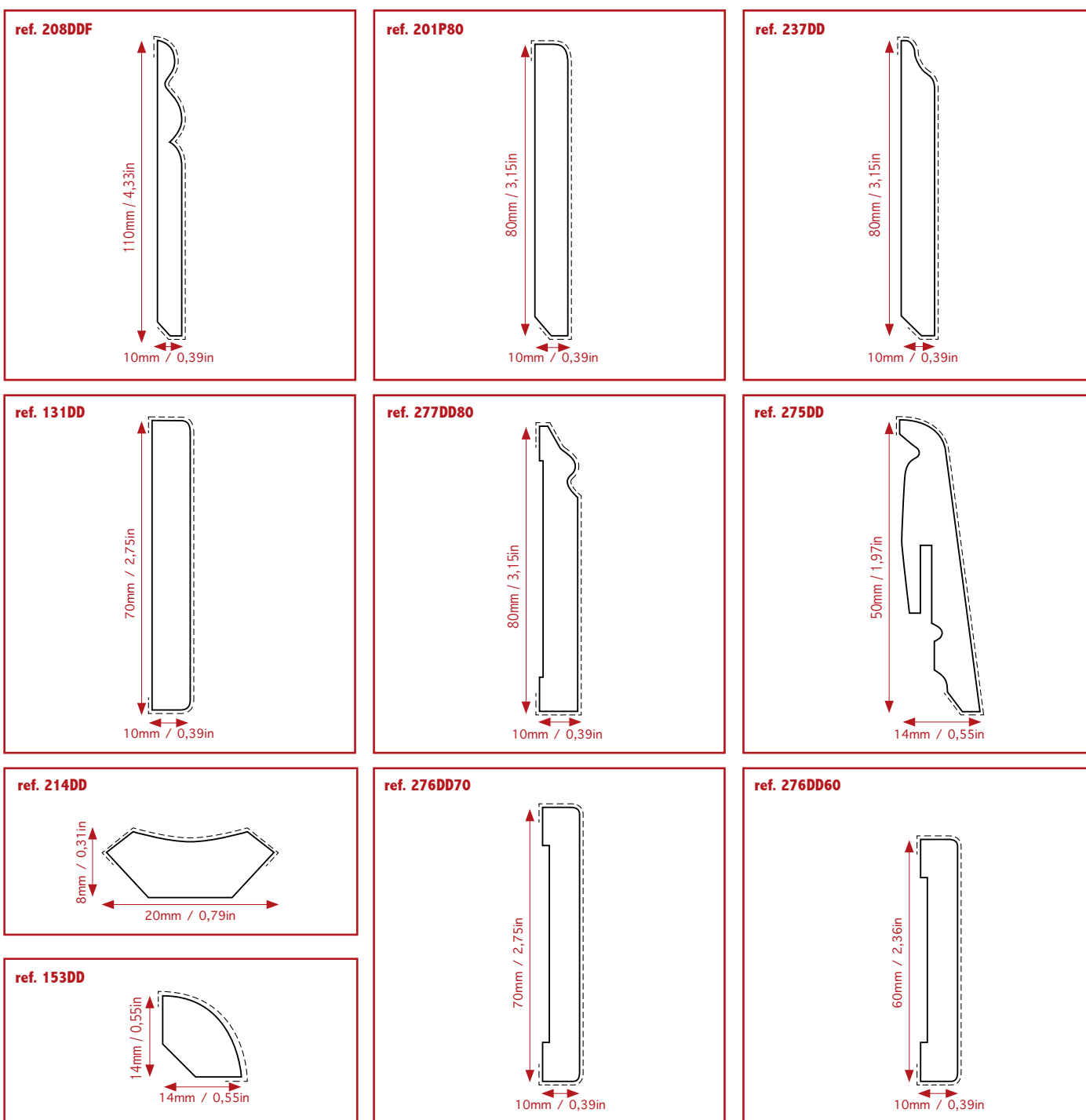

WOOD VENEER / PLACAGE BOIS

WOOD SECTION / SECTION BOIS



wood veneers from around the world

www.perfilstar.com

WOOD VENEER SKIRTING / PLINTE PLACAGE BOIS





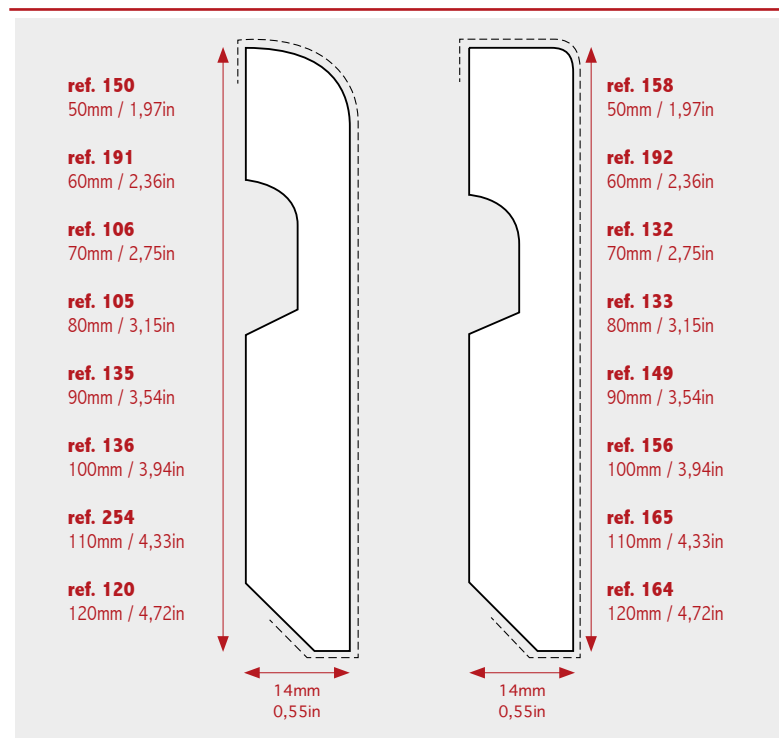

Technical Features / Caracteristiques Techniques

Finish / Finition	Wood veneer / Placage bois
Support / Support	Pine / Pin // MDF / MDF
Adhesive / Adhésif	EVA or PUR / EVA ou PUR
Length / Longueur	2200 mm / 86,61 in

Measures / Mesures



Pine Finger Joint / Pin Abouté 
 MDF 
 Plywood / Contreplaqué 
 Moisture resistant MDF / MDF Hidrofuge 

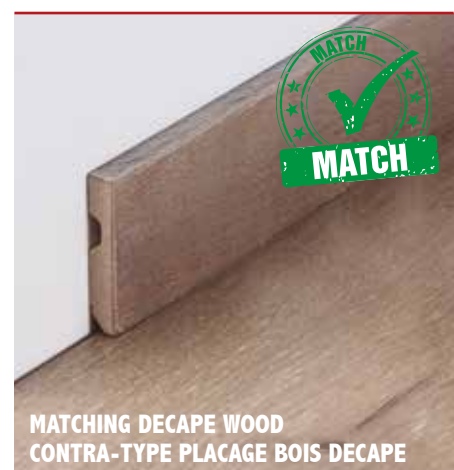
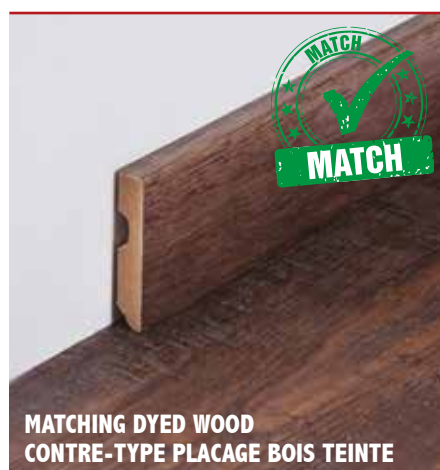

WOOD VENEER FINISHES / SOLUTION PLACAGE BOIS



RAW WOOD

Oak raw veneer
Placage de chêne brut



NATURAL VARNISH WOOD

Oak varnish veneer
Placage de chêne vernis



DYED WOOD

Oak dyed veneer
Chêne teinté



DECAPE WOOD

Oak decapé veneer
Placage de chêne



AMERICAN WOODS

Walnut, sucupira, jatoba...
Noyer, sucupira, jatoba...



AFRICAN WOODS

Embero, Iroko, Sapelly...
Embero, Iroko, Sapelly...



EUROPEAN WOODS

Oak, beech, cherry...
Chêne, hêtre, cerisier...



ASIAN WOODS

Teak, Merbau...
Teck, Merbau...



VENEER MATCHING
CORRESPONDANCE DE PLACAGE BOIS



ANY TYPE OF WOOD
TOUT TYPE DE BOIS



WOOD MDF HIDRO JOINTS / BARRE DE SEUIL MDF HIDRO PLACAGE DE BOIS

Technical Features / Caracteristiques Techniques

Finish / Finition	Wood veneer / Placage bois
Support / Support	Moisture resistant MDF / MDF Hidrofuge
Length / Longueur	2440 mm / 96,06 in
Adhesive / Adhésif	PUR / PUR

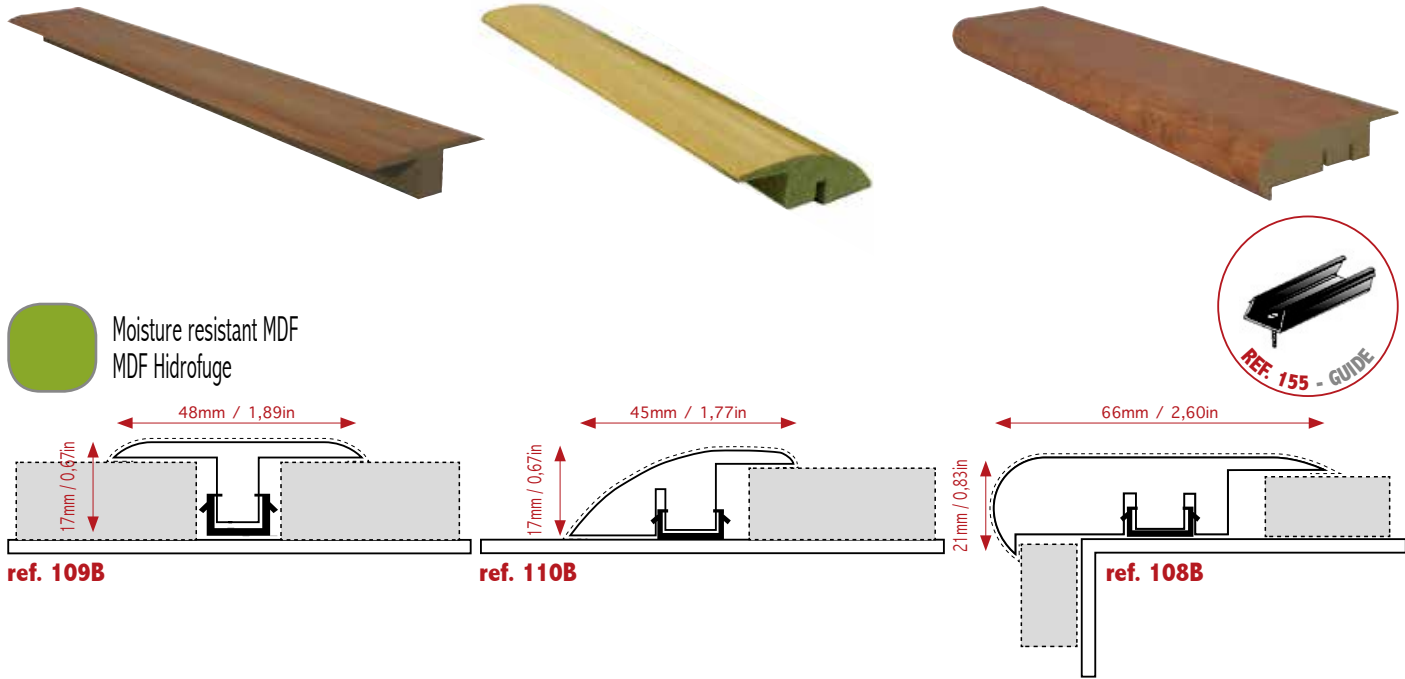

WOOD ALUMINIUM JOINTS / BARRE DE SEUIL ALUMINIUM PLACAGE BOIS

Technical Features / Caracteristiques Techniques

Finish / Finition	Wood veneer / Placage bois
Support / Support	Aluminium / Aluminium
Length / Longueur	2700 mm / 106,30 in
Adhesive / Adhésif	PUR / PUR

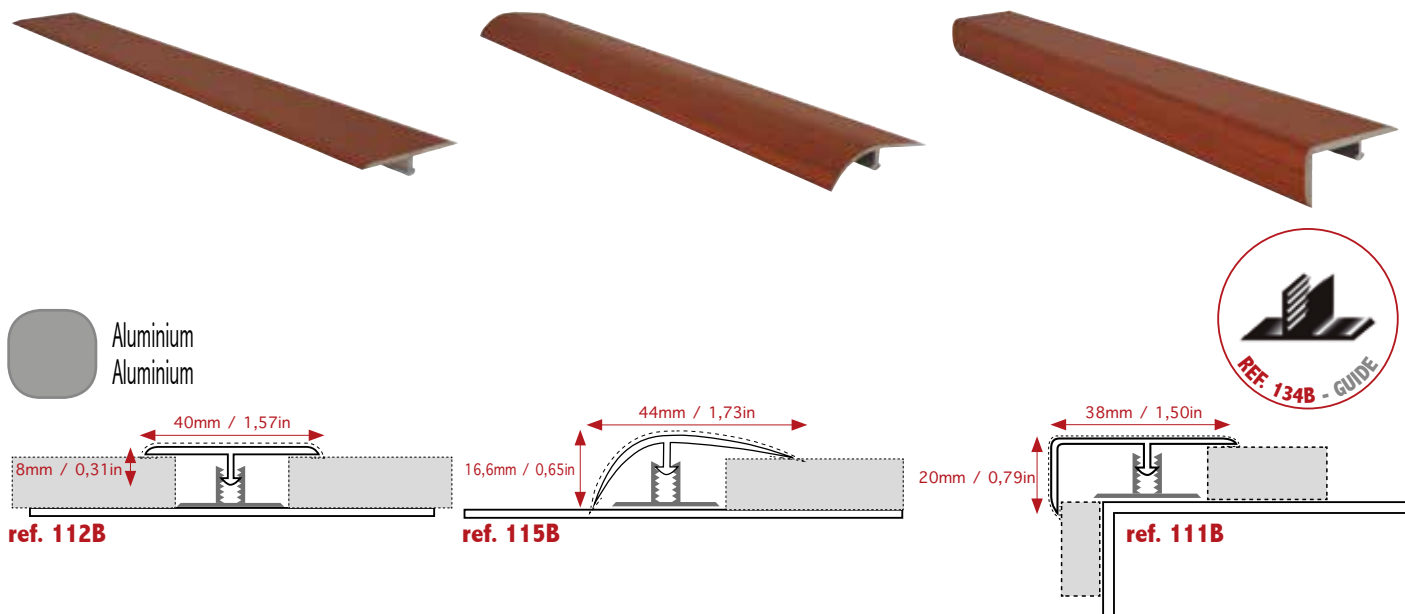

LACQUERED SKIRTING / PLINTHE LAQUÉE

LACK SECTION / SECTION DE LAQUÉE





all lacquering colors

LACQUERED SKIRTING / PLINTHE LAQUÉE



MDF White Lacquered Laquée Blanc MDF

-  MDF
MDF
-  Moisture resistant MDF
MDF Hidrofuge



Lacquered Laquée



Prelacq MDF Prelaquée MDF



Lacquered Pine Pin Laquée

-  Pine Finger Joint
Pin Abouté

Measures / Mesures

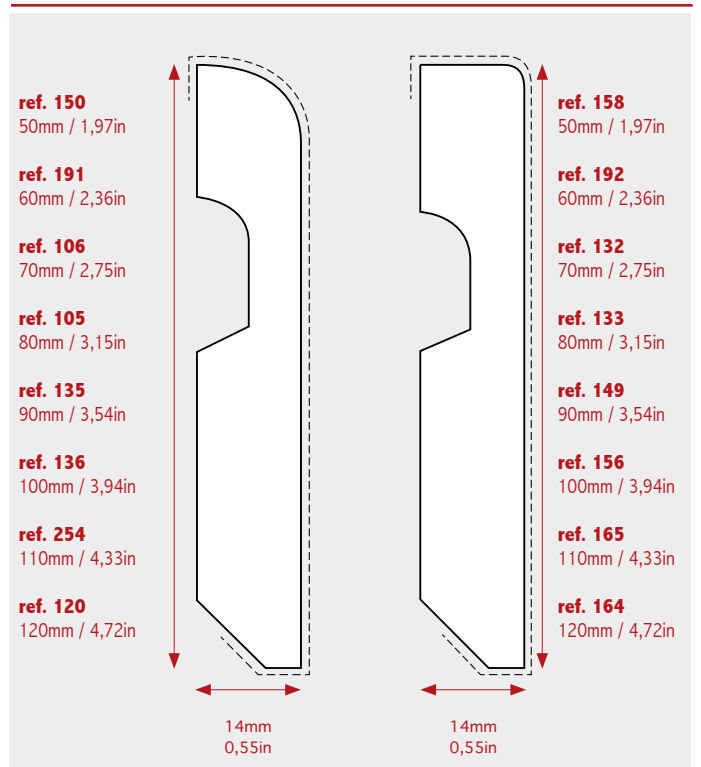

ALUMINIUM AND INOX STEEL / ALUMINIUM ET ACIER INOX

METALL SECTION / SECTION DE METAL



real aluminium

METALLIC SKIRTING / PLINTE METALLIQUE

Technical Features / Caracteristiques Techniques

Finish / Finition	Aluminium, Inox Steel or Copper / Aluminium, Acier Inox ou Cobre
Support / Support	MDF / MDF
Adhesive / Adhésif	PUR / PUR
Length / Longueur	2250 mm / 88,5 in

Measures / Mesures

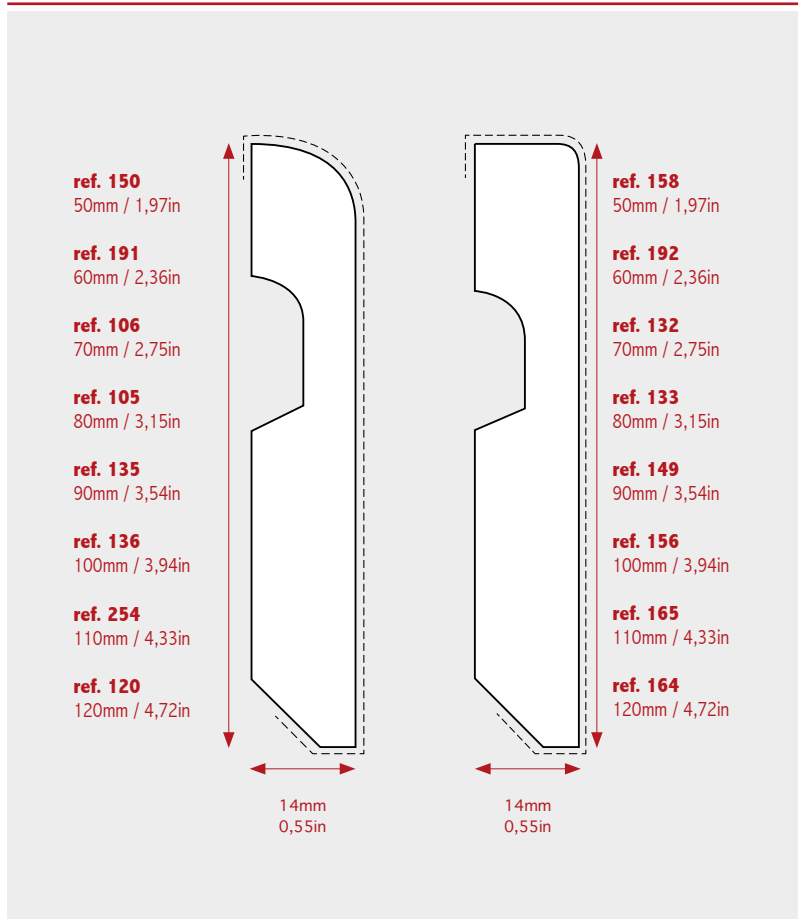

MDF 
MDF 
Moisture resistant MDF 
MDF Hidrofuge 



■ MASSIF METALLIC / METALLIQUE MASSIF

Technical Features / Caracteristiques Techniques

Finish / Finition	Aluminium or Inox Steel or white or Digital laminate / Aluminium ou Acier Inox ou Blanc ou Stratifié digital
Support / Support	MDF / MDF
Adhesive / Adhésif	PUR / PUR
Length / Longueur	2700 mm / 106,30 in



Measures / Mesures

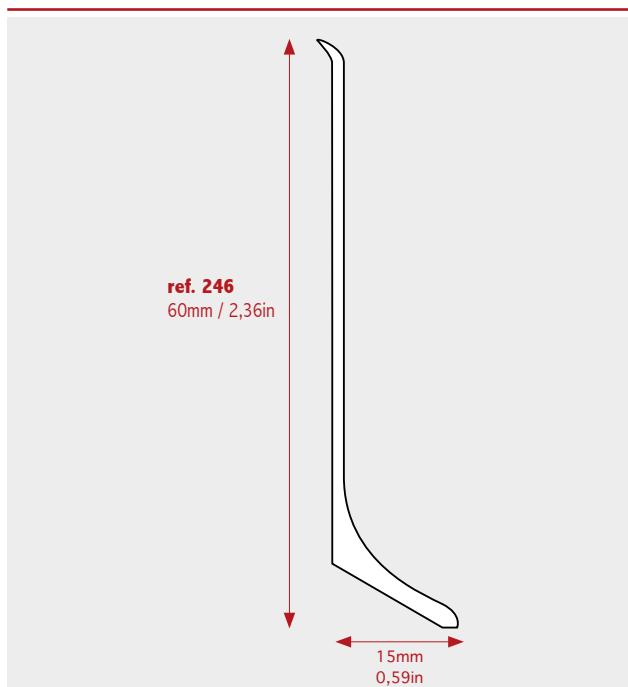

ref. 249



MASSIF JOINT
BARRE DE SEVIL MASSIF

ref. 116



MASSIF JOINT
BARRE DE SEVIL MASSIF

ref. 236



MASSIF JOINT
BARRE DE SEVIL MASSIF

Ask for samples Demander echanti-



 ref. 105 80mm / 3,15in 14mm / 0,55in	 ref. 105RIB1 80mm / 3,15in 14mm / 0,55in	 ref. 106 70mm / 2,75in 14mm / 0,55in	 ref. 106RIB1 70mm / 2,75in 14mm / 0,55in	 ref. 108A 22mm / 0,87in 68mm / 2,68in	 ref. 108B 21mm / 0,83in 66mm / 2,60in	 ref. 109A 10mm / 0,39in 48mm / 1,89in	 ref. 110A 10mm / 0,39in 48mm / 1,89in
 ref. 110B 17mm / 0,67in 45mm / 1,77in	 ref. 111A 20mm / 0,79in 38mm / 1,50in	 ref. 112A 8mm / 0,31in 40mm / 1,58in	 ref. 113A 13mm / 0,5in 39mm / 1,53in	 ref. 114 10mm / 0,39in 25mm / 0,98in	 ref. 116 6,6mm / 0,26in 38mm / 1,50in	 ref. 117A 10mm / 0,39in 32mm / 1,26in	 ref. 120 120mm / 4,72in 14mm / 0,55in
 ref. 120RIB1 120mm / 4,72in 14mm / 0,55in	 ref. 121MY 80mm / 3,15in 14mm / 0,55in	 ref. 121P 85mm / 3,35in 14mm / 0,55in	 ref. 131DD 70mm / 2,75in 10mm / 0,39in	 ref. 132 70mm / 2,75in 14mm / 0,55in	 ref. 132RIB1 70mm / 2,75in 14mm / 0,55in	 ref. 133 80mm / 3,15in 14mm / 0,55in	 ref. 133RIB1 80mm / 3,15in 14mm / 0,55in
 ref. 135 90mm / 3,54in 14mm / 0,55in	 ref. 135RIB1 90mm / 3,54in 14mm / 0,55in	 ref. 136 100mm / 3,94in 14mm / 0,55in	 ref. 136RIB1 100mm / 3,94in 14mm / 0,55in	 ref. 149 90mm / 3,54in 14mm / 0,55in	 ref. 149RIB1 90mm / 3,54in 14mm / 0,55in	 ref. 150 50mm / 1,97in 14mm / 0,55in	 ref. 150RIB1 50mm / 1,97in 14mm / 0,55in
 ref. 152K 35mm / 1,38in 35mm / 1,38in	 ref. 153 14mm / 0,55in 14mm / 0,55in	 ref. 156 100mm / 3,94in 14mm / 0,55in	 ref. 156RIB1 100mm / 3,94in 14mm / 0,55in	 ref. 157P70 70mm / 2,75in 14mm / 0,55in	 ref. 157P80 80mm / 3,15in 14mm / 0,55in	 ref. 158 50mm / 1,97in 14mm / 0,55in	 ref. 158RIB1 50mm / 1,97in 14mm / 0,55in
 ref. 162P70 70mm / 2,75in 14mm / 0,55in	 ref. 162P80 80mm / 3,15in 14mm / 0,55in	 ref. 164 120mm / 4,72in 14mm / 0,55in	 ref. 164RIB1 120mm / 4,72in 14mm / 0,55in	 ref. 165 110mm / 4,33in 14mm / 0,55in	 ref. 165RIB1 110mm / 4,33in 14mm / 0,55in	 ref. 185FR80 80mm / 3,15in 12mm / 0,47in	 ref. 185FR90 90mm / 3,54in 12mm / 0,47in
 ref. 185FR100 100mm / 3,94in 12mm / 0,47in	 ref. 191 60mm / 2,36in 14mm / 0,55in	 ref. 191RIB1 60mm / 2,36in 14mm / 0,55in	 ref. 192 60mm / 2,36in 14mm / 0,55in	 ref. 192MGE40 40mm / 1,57in 15mm / 0,59in	 ref. 192MGE60 60mm / 2,36in 15mm / 0,59in	 ref. 192MGE80 80mm / 3,15in 15mm / 0,59in	 ref. 192RIB1 60mm / 2,36in 14mm / 0,55in
 ref. 197 14mm / 0,55in 14mm / 0,55in	 ref. 201P50 50mm / 1,97in 10mm / 0,39in	 ref. 201P60 60mm / 2,36in 10mm / 0,39in	 ref. 201P70 70mm / 2,75in 10mm / 0,39in	 ref. 201P80 80mm / 3,15in 10mm / 0,39in	 ref. 201P90 90mm / 3,54in 10mm / 0,39in	 ref. 201P100 100mm / 3,94in 10mm / 0,39in	 ref. 201P110 110mm / 4,33in 10mm / 0,39in
 ref. 201P120 120mm / 4,72in 10mm / 0,39in	 ref. 204P50 50mm / 1,97in 15mm / 0,59in	 ref. 204P60 60mm / 2,36in 15mm / 0,59in	 ref. 204P70 70mm / 2,75in 15mm / 0,59in	 ref. 204P80 80mm / 3,15in 15mm / 0,59in	 ref. 204P90 90mm / 3,54in 15mm / 0,59in	 ref. 204P100 100mm / 3,94in 15mm / 0,59in	 ref. 204P110 110mm / 4,33in 15mm / 0,59in
 ref. 204P120 120mm / 4,72in 15mm / 0,59in	 ref. 208 133mm / 5,24in 14mm / 0,55in	 ref. 208DD 110mm / 4,33in 14mm / 0,55in	 ref. 208DM160 160mm / 6,30in 14mm / 0,55in	 ref. 214DD 8mm / 0,3in 20mm / 0,79in	 ref. 214UK 16mm / 0,63in 16mm / 0,63in	 ref. 218 118mm / 8,58in 14mm / 0,55in	 ref. 219 65mm / 2,55in 14mm / 0,55in
 ref. 220 18mm / 0,71in 18mm / 0,71in	 ref. 229QD 48mm / 1,89in 22mm / 0,87in	 ref. 233P180 180mm / 7,08in 14mm / 0,55in	 ref. 235 5mm / 0,2in 40mm / 1,57in	 ref. 236 7mm / 0,27in 41mm / 1,61in	 ref. 237DD 80mm / 3,15in 10mm / 0,39in	 ref. 246 60mm / 2,36in 15mm / 0,59in	 ref. 249 2mm / 0,08in 40mm / 1,58in
 ref. 254 110mm / 4,33in 14mm / 0,55in	 ref. 254RIB1 110mm / 4,33in 14mm / 0,55in	 ref. 272W 60mm / 2,36in 15mm / 0,59in	 ref. 275DD 50mm / 1,97in 22mm / 0,87in	 ref. 275DM50 50mm / 1,97in 14mm / 0,55in	 ref. 276DD60 60mm / 2,36in 10mm / 0,39in	 ref. 276DD70 70mm / 2,75in 10mm / 0,39in	 ref. 277D80 80mm / 3,15in 10mm / 0,39in

Consult us for other profiles or finishes / Nous consulter pour d'autres profils ou finitions

WHITE SKIRTINGS / PLINTE BLANCHE



ref. L-2322

White lacquered laminate

Blanc lacquée stratifié



ref. L-0

RAL 9003

Ready to Paint

Prêt a peindre

ref. L-99

RAL 9003

White Laminate

Blanc Stratifié



ref. CHO

White pre Lacquered

Blanc Lacquée pret-â-peindre



ref. CH99

White Lacquered

Blanc Lacquée



ref. P07

PVC white

Blanc PVC



ref. P945

PVC White Lacquered

PVC Blanc Lacquée



ref. P946

PVC Veralinga White

PVC Veralinga Blanc



ref. P953

PVC Move Alaska

PVC Move Alaska

Measures / Mesures

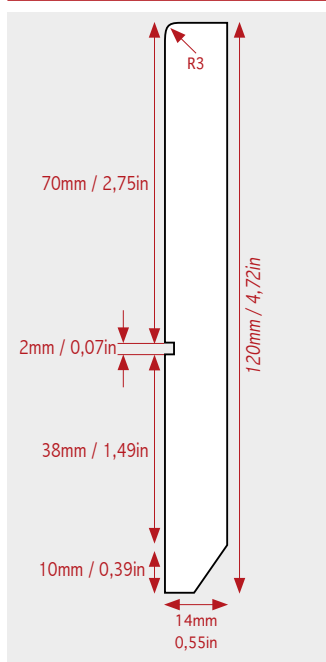

ref. 221B



Support / Support

- MDF
- Pine
- Plywood

Finish / Finition

- Laminate
- Lacquered
- Metallic

Measures / Mesures

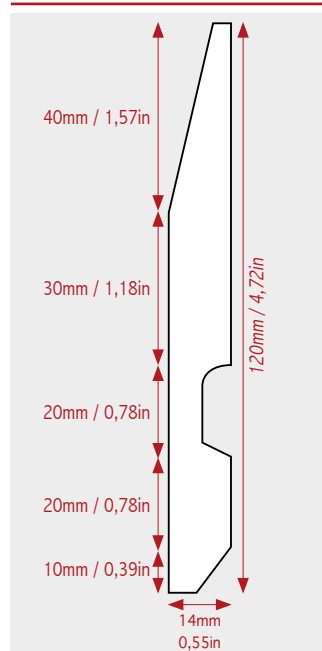

ref. 239



Support / Support

- MDF
- Pine
- Plywood

Finish / Finition

- Laminate
- Lacquered
- Metallic

Profile on Demand

Measures / Mesures

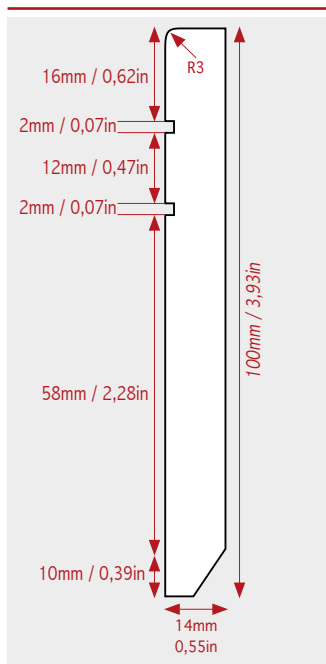

ref. 221C



Support / Support

- MDF
- Pine
- Plywood

Finish / Finition

- Laminate
- Lacquered
- Metallic

Measures / Mesures

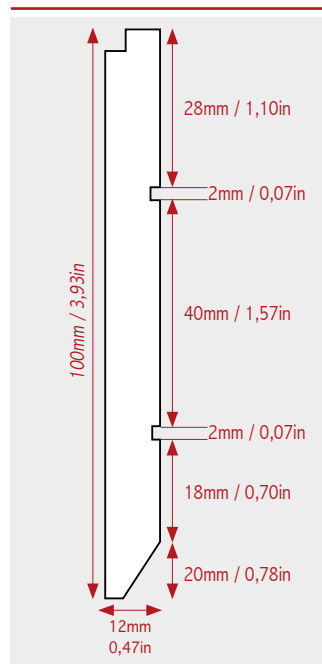

ref. 221D



Support / Support

- MDF
- Pine
- Plywood

Finish / Finition

- Laminate
- Lacquered
- Metallic

diy



Product for **BRICO DIY**

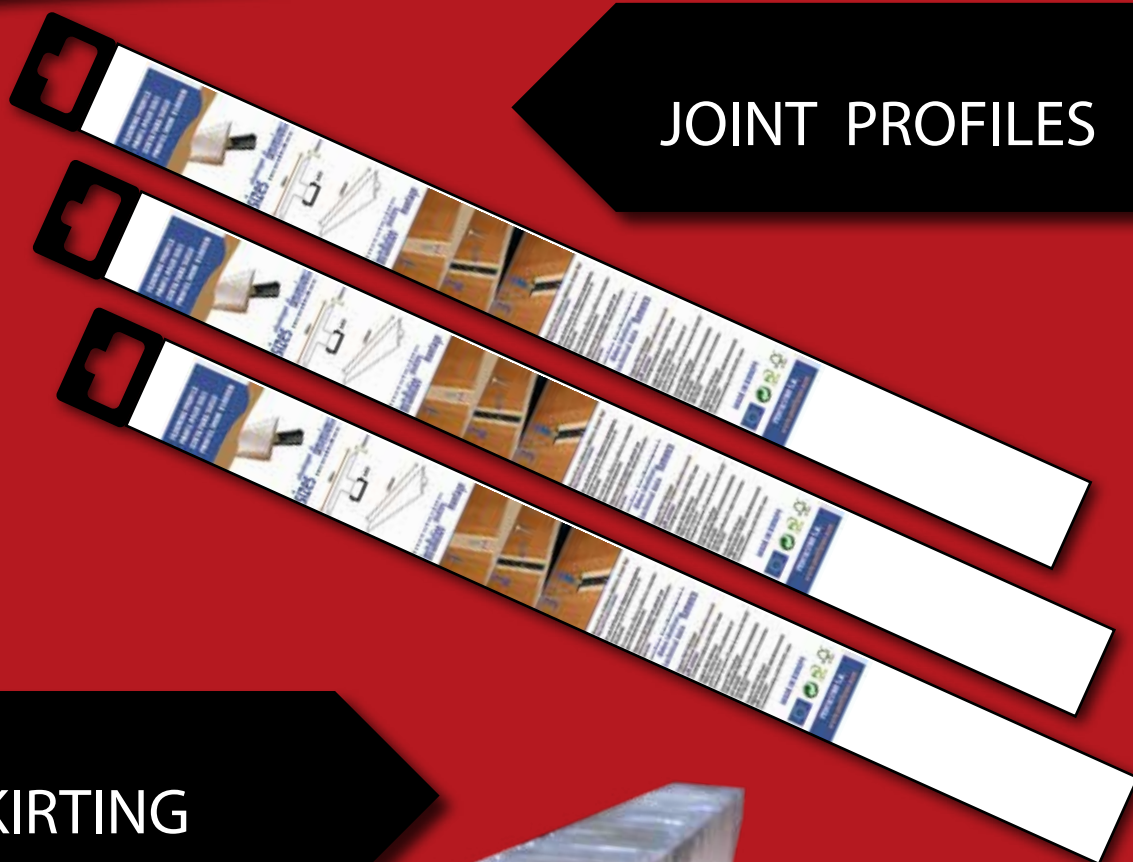

JOINT PROFILES

SKIRTING



**SPECIAL
PRICES**

WALL PANEL / PANNEAU MURAL

WALL SECTION / SECTION DE REVÊTEMENTS MURAUX



best designs of the wall

STARWOOD

Technical Features / Caracteristiques Techniques

Oak veneer / Placage chêne

Support MDF / MDF Support

Different finishes / Différentes finitions

Self-adhesive / Auto-adhésif

Combinable models / Modèles combinables

Multiple applications for DIY / Applications multiples pour le bricolage



SAMPLES
ÉCHANTILLONS



PACKAGING
EMBALLAGE

800mm / 31,49in

ref. 260P800



115mm / 4,58in





STARPANEL

STARPANEL W300

Technical Features / Caracteristiques Techniques

Emboss Decorative Polypropilene Film with unique visual and haptic design
 Effet decoratif en Polypropilene avec un effet visuel unique et tacte incomparable

Antihumidity Polyurethane Reactive glue / Colle Polyurethane Reactive Antihumidité

Medium Density Fibres Support / MDF Support

Scratch and abrasion-resistant / Resistant aux rayures et a l'abrasion

Unique combination of embossing and print / Combination unique de relief et d'impression

Water and steam-resistant / Resistant a l'eau et la vapeur



SAMPLES ÉCHANTILLONS



PACKAGING EMBALLAGE

2720mm / 107,09in



297mm / 11,69in
 long board

ref. 141



ref. 133

80mm / 3,15in
 14mm / 0,55in

ref. 152K

35mm / 1,38in
 35mm / 1,38in

ref. 272W

60mm / 2,36in
 15mm / 0,59in



P406 LOIRE ASH NATURAL P



P425 PAGESA CHERRY NATURAL P



P606 VERADE OAK NATURAL



P693 SILVER AMARI



P826 ME RIBEIRA ASH CREAM



P827 ME SWISS ELM DARK TWEEDY



P829 ME PAMPLONA NATURAL TWEEDY



P858 MOUNTAIN LARCH CAPPUCCINO



P876 LOIRE ASH WHITE P CROSSCUT



P921 PACIFIC B



P945 BLANCO LACA



P946 VERALINGA ALASKA WHITE



P953 MOVE ALASKA WHITE MATT



P954 AMBERES OAK LIGHT GREY



P955 ANDERSEN PINE RUSTIC

STRIP CEILING DECORATION / BANDE DE DÉCORATION

Technical Features / Caractéristiques Techniques

Finish / Finition	Digital laminate and PVC / Stratifié digital et PVC
Support / Support	MDF / MDF
Adhesive / Adhésif	PUR / PUR
Length / Longueur	2400 mm / 94,48 in



Measures / Mesures

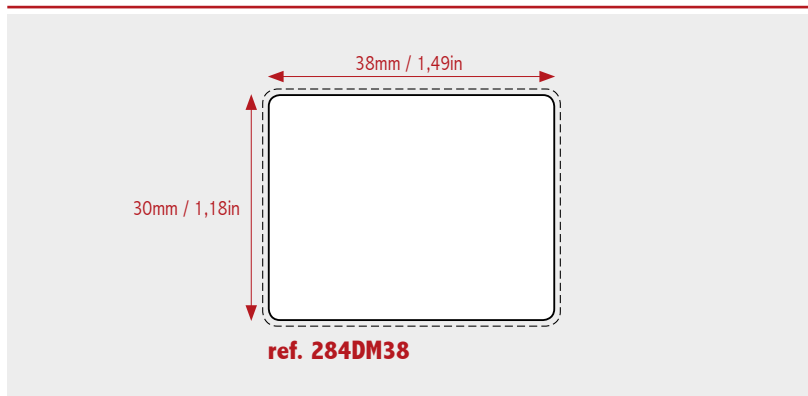



CEILING DECOR PROFILE

DOOR FRAME PROFILE / PROFIL DE CADRE DE PORTE

DOOR SECTION / SECTION PORTES



hold the door, hold the door

www.perfilstar.com



DOOR FRAME PROFILE / PROFIL CADRE DE PORTE

Technical Features / Caracteristiques Techniques

PVC Compact / PVC Compact	Support / Support	MDF / MDF
PUR / PUR	Adhesive / Adhésif	EVA / EVA
2250 mm / 88,58 in	Length / Longueur	2250 mm / 88,58 in

The technical drawing shows three rows of door frame profiles. Each row has a central vertical profile with dimensions and two side views. The dimensions are: 9mm (0,35in) for the top row, 12mm (0,47in) for the middle row, and 15mm (0,59in) for the bottom row. The profiles are labeled with reference numbers and dimensions in millimeters and inches.

Reference	Dimensions	Material
ref. 122PVC70	70mm / 2,75in	Compact PVC
ref. 122DM70	70mm / 2,75in	MDF
ref. 122PVC80	80mm / 3,15in	Compact PVC
ref. 122DM80	80mm / 3,15in	MDF
ref. 122PVC90	90mm / 3,54in	Compact PVC
ref. 122DM90	90mm / 3,54in	MDF
ref. 122PVC100	100mm / 3,94in	Compact PVC
ref. 122DM100	100mm / 3,94in	MDF
ref. 123PVC70	70mm / 2,75in	Compact PVC
ref. 123DM70	70mm / 2,75in	MDF
ref. 123PVC80	80mm / 3,15in	Compact PVC
ref. 123DM80	80mm / 3,15in	MDF
ref. 123PVC90	90mm / 3,54in	Compact PVC
ref. 123DM90	90mm / 3,54in	MDF
ref. 123PVC100	100mm / 3,94in	Compact PVC
ref. 123DM100	100mm / 3,94in	MDF
ref. 124PVC70	70mm / 2,75in	Compact PVC
ref. 124DM70	70mm / 2,75in	MDF
ref. 124PVC80	80mm / 3,15in	Compact PVC
ref. 124DM80	80mm / 3,15in	MDF
ref. 124PVC90	90mm / 3,54in	Compact PVC
ref. 124DM90	90mm / 3,54in	MDF
ref. 124PVC100	100mm / 3,94in	Compact PVC
ref. 124DM100	100mm / 3,94in	MDF

Compact PVC
 PVC Compact

MDF
 MDF
 Moisture resistant MDF
 MDF Hidrofuge

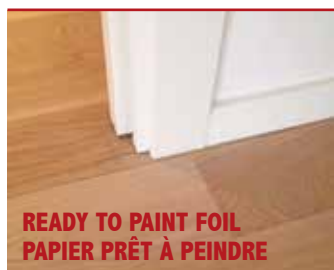

DIGITAL FOIL / PAPIER DIGITAL

DIGITAL SECTION / SECTION DIGITAL

all you can imagine can be printed



www.perfilstar.com

DIGITAL FOIL / PAPIER DIGITAL

Technical Features / Caracteristiques Techniques

Customized decor	Décor personnalisé
More than 3.000 decors in catalogue	Plus de 3.000 décors du contretypés
Little quantities per decor	Petites quantités par décor
Pre-impregnated base foil 60 g/sqm	Papier digital pré-imprégné 60 g/m ²
UV ink + UV varnish	UV imprimé + Vernis UV
Formaldehyde free	Papier sans formaldéhyde

Digital painting lines / Lignes d'impression digital



Varnish lacquering line / Ligne de vernissage



Quality / Qualité



Barcelona - Spain - Europe



Perfilstar S.A. is a factory that manufactures complements for floors, walls and ceilings. We supply accessories for laminate flooring, wood parquet and LVT/Vinyl/SPS floor.

The company was founded in 1994. More than 25 years of experience wrapping mouldings. Nowadays located in Barberà del Vallés (Barcelona) we have about 7.000 square meters facilities where we can assume more than 20 millions lineal meters of moulding production. With our flexibility we can produce an extended portfolio of products.

First company in use Digital printing for full production of our profile decors and 40 million lineal meters digitally printed the last years. More than 4.000 decor designs available and coating lines to do any kind of finish. Our manufacturing lines are completely automatized for a non-stop production.

Perfilstar S.A. est une usine qui fabrique des compléments pour les sols, les murs et les plafonds. Nous fournissons des accessoires pour les sols stratifiés, les parquets en bois et les sols LVT / Vinyle / SPS.

La société a été fondée en 1994. Plus de 25 ans d'expérience dans l'emballage de moulures. Actuellement situés à Barberà del Vallés (Barcelone), nous disposons d'installations d'environ 7 000 mètres carrés où nous pouvons assumer plus de 20 millions de mètres linéaires de production de moulures. Grâce à notre flexibilité, nous pouvons produire un portefeuille étendu de produits.

Première entreprise en activité Impression numérique pour la production complète de nos décors de profil et de 40 millions de compteurs linéaires imprimés numériquement les dernières années. Plus de 4 000 décors et lignes de revêtement disponibles pour tous les types de finitions. Nos lignes de fabrication sont entièrement automatisées pour une production en continu.

We EXPORT more than 50 countries worldwide / Nous EXPORTONS dans plus de 50 pays



We are focus on a QUALITY product / La QUALITÉ produit est notre priorité



and improve with AUTOMATIZATION of the factory / et se perfectionne grâce à l'AUTOMATISATION des machines



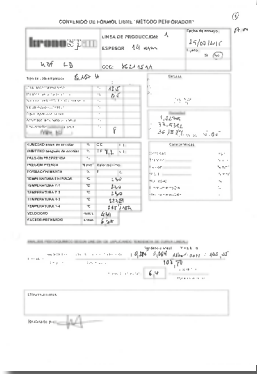

CARB CERTIFICATE

We love our planet and we care about its conservation, contributing to maintain the biodiversity and ecological processes of our forests using resources that respect the environment. Our raw material is CARB2 certified. Manufactured for our suppliers achieve a low level of formaldehyde.

Nous aimons notre planète et nous nous soucions de sa conservation, en contribuant à maintenir la biodiversité et les processus écologiques de nos forêts en utilisant des ressources respectueuses de l'environnement. Notre matière première est certifiée CARB2. Fabriqué par nos fournisseurs et qui contient atteindre un faible niveau de formaldéhyde.



PEFC CERTIFICATE

Our products are PEFC certified to ensure the wood origin and preservation of forest environment. We make controlled and conscious use of our resources related to wood, using PEFC certificate that identifies us as a company committed to our planet and its conservation. PEFC grants this certificate to companies that avoid the purchase of illegal timber and the massive felling of trees.

Nos produits sont certifiés PEFC pour assurer l'origine du bois et la préservation de l'environnement forestier. Nous utilisons de manière contrôlée et consciente nos ressources liées au bois, en utilisant le certificat PEFC qui nous identifie comme une entreprise engagée envers notre planète et sa conservation. PEFC accorde ce certificat aux entreprises qui évitent l'achat de bois illégal et l'abattage massif d'arbres.

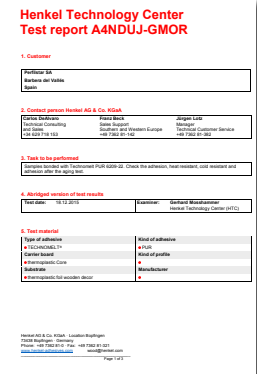

ADHESIVE TESTS

The most sensitive part of our manufacture for this reason we check constantly with laboratory tests and we work with top suppliers.

La partie la plus sensible de notre fabrication est l'adhésif. C'est pour cette raison que nous contrôlons constamment avec des tests de laboratoire et que nous travaillons avec les meilleurs fournisseurs.



GREEN POINT

Aware of need to preserve and improve the environment. Perfilstar believe in recycling so we do have partnership with Green Point Association in accordance with sustainability criteria.

Conscient de la nécessité de préserver et d'améliorer l'environnement. Perfilstar croit au recyclage, nous avons donc un partenariat avec la Green Point Association conformément aux critères de durabilité.



BAR CODE REGISTRATION

In order to have a good traceability of our products and to ease the managing of our partners of DIY and brico warehouses we are AECOC associate.

Pour assurer une bonne traçabilité de nos produits et faciliter la gestion de nos partenaires d'entrepôts de bricolage et de brico, nous sommes associés à AECOC.

EAN 13

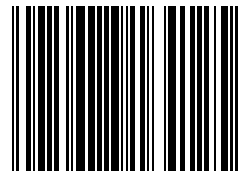

LABORATORY TEST

Responsibility and continuous improvement of the quality of our products and services by part of our entire team. We control our products with continuous tests inner and outer laboratories.

Responsabilité et amélioration continue de la qualité de nos produits et services par une partie de notre équipe. Nous contrôlons nos produits avec des tests continus en laboratoire interne et externe.



Since 1920

We are in the wood and furniture sector since 1920. First with a veneer wood warehouse, in next generation building furnitures, and the recent history producing mouldings for flooring.

À partir de 1920

Nous sommes dans le négoce du bois et des meubles depuis 1920. En premier lieu avec un dépôt de placage bois, et la génération suivante dans le monde du meuble et actuellement nous produisons des accessoires pour tous types de parquets.





Headquarter Factory

PERFILSTAR S.A.

Av. Torre Mateu, 77, naves 4, 5, 6 - P.I. Can Salvatella
08210 Barberà del Vallès (Barcelona) - Spain
Tel. 93 729 11 39 - Fax 93 719 20 44
perfilstar@perfilstar.com



Lackering Factory

PERFILSTAR S.A.

C/ Flassaders, 13-15, naves 9, 10 - P.I. Santiga
08130 Santa Perpètua de Mogòda (Barcelona) - Spain
Tel. 93 729 11 39 - Fax 93 719 20 44
perfilstar@perfilstar.com



www.perfilstar.com

